



# PM Fenders.

## Characteristics

- ▶ Equal energy absorption capacity at any impact level
- ▶ The torsion resistant arm of the system allows only parallel panel movements and eliminates a second ship/panel contact
- ▶ Reaction forces could be substantially lower for back-to-back rubber unit configuration
- ▶ Lower reaction forces lead to lower hull pressure and lighter berth substructures, which reduces the overall project cost

## Applications

- ▶ Bulk Terminals
- ▶ Oil & Gas Terminals
- ▶ Ferry & RoRo Terminals
- ▶ Monopiles
- ▶ Load sensitive structures

Parallel Motion Fenders are highly customized systems. Therefore, no standard dimensions and values can be provided. Please contact us for detailed information, calculations and assistance for the design.

## PM FENDER DRAWING

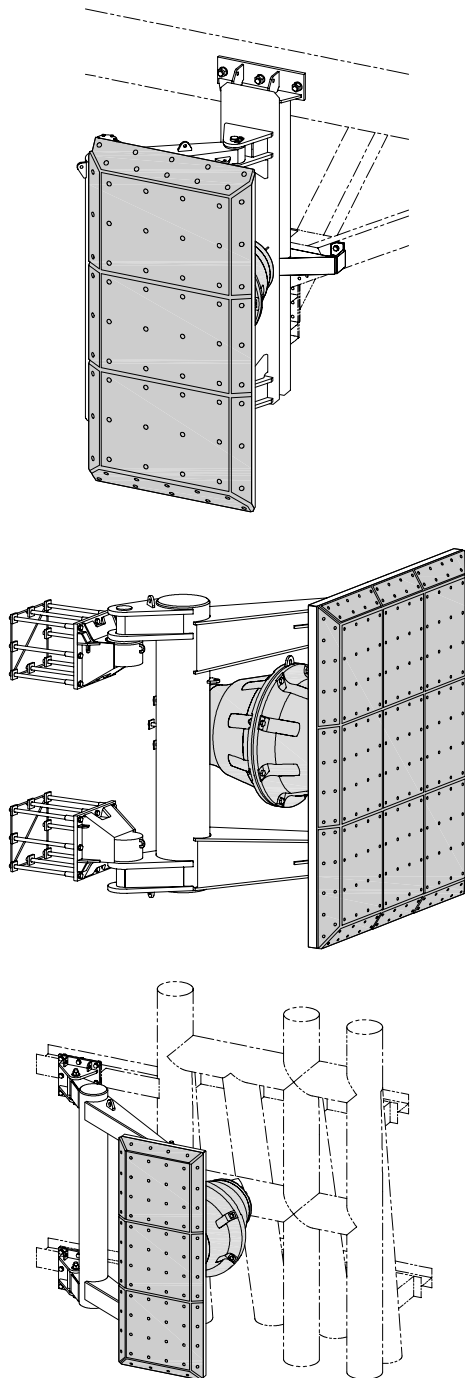

Ferry Berth | Hirtshals | Denmark



Oil Terminal | Labuan | Malaysia



Esso Terminal | Paramaribo | Surinam